

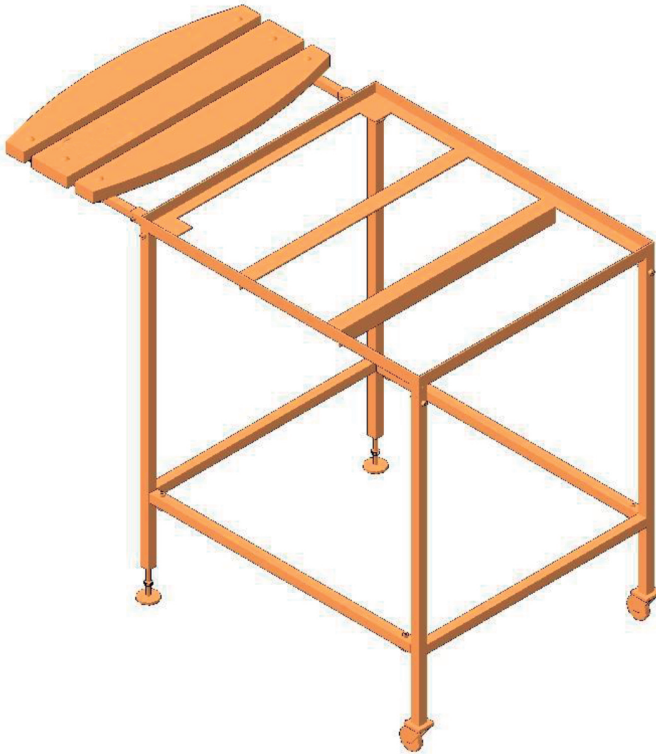

GIRtech



BASE

TABLE FOR MULTIFUNCTIONAL
BRAVO WOOD OVEN

ASSEMBLY INSTRUCTIONS

MAIN ELEMENTS OF THE TABLE





The table is delivered disassembled. Each of the component parts is numbered 1 to 9. The details are shown in the figure.

A complete set contains the following parts:

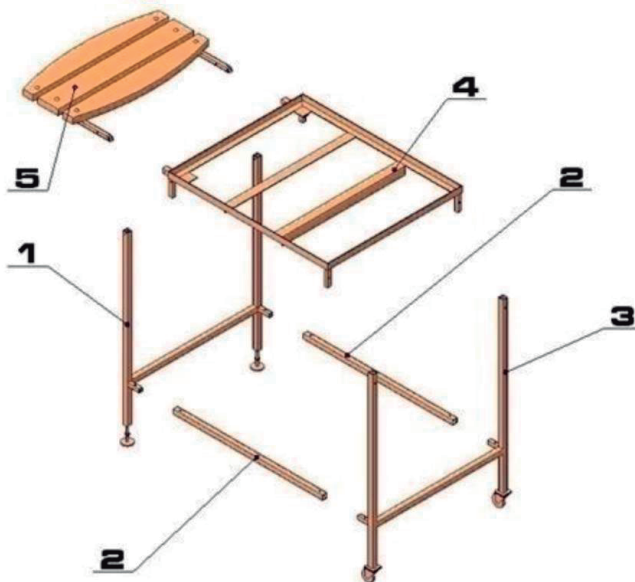
1. Table construction elements - 6 pcs.
2. Bolt M6x30 - 6 pcs.
3. Bolt M6x50 - 2 pcs.
4. Nut M6 - 8 pcs.
5. Hex key - 1 pc.

SET VIEW



6 Bolt M6x30  6 pcs.	7 Bolt M6x50  2 pcs.	8 Nut M6x  6 pcs.	9 Hex key  1 pc.
---	---	---	--

The assembly process comprises of 4 stages and the table can be assembled by one-man. The table shall be assembled exactly according to the scheme presented below. The assembled parts are shown in gray. The parts are to be assembled are shown in orange.

Caution! When assembling the structure, keep small parts out of sight of the children as they can swallow them and choke.

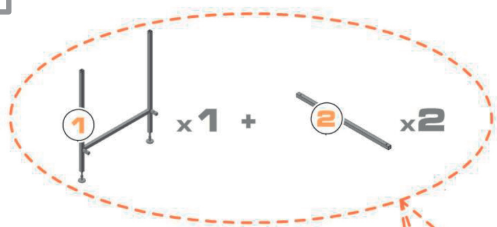
1

Mount part №1 on a solid surface, assemble two parts №2 and tighten bolts №6 and nuts №8 with hex key №9

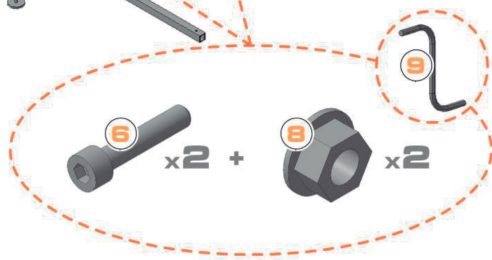
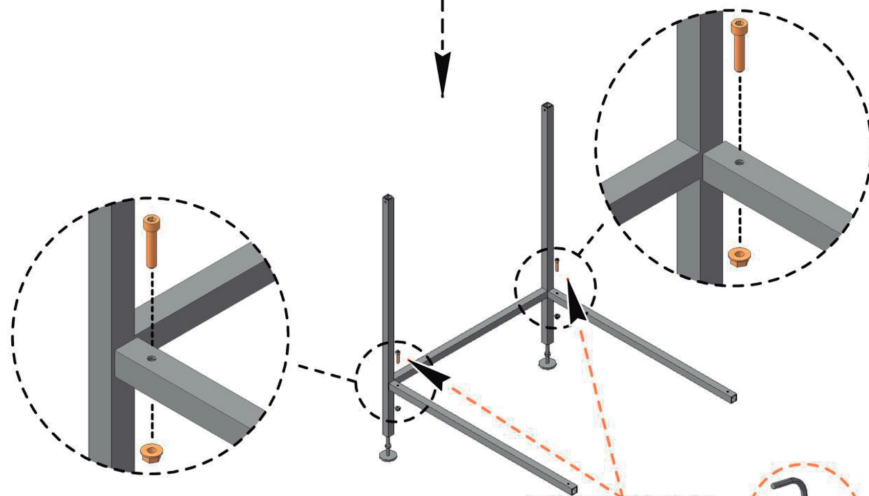
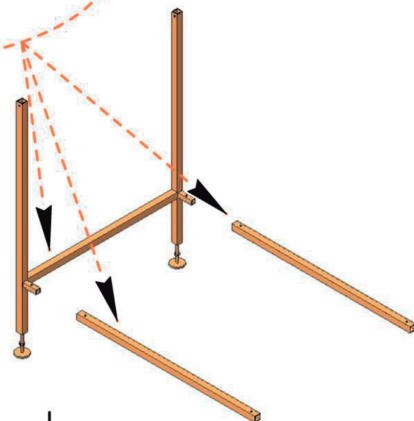

2

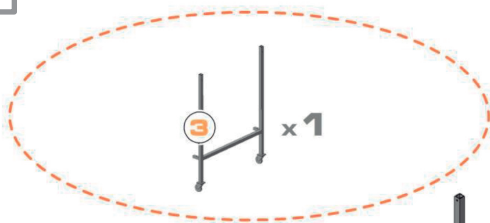

Fasten parts №3 with bolts №6 and nuts №8 using hex key №9

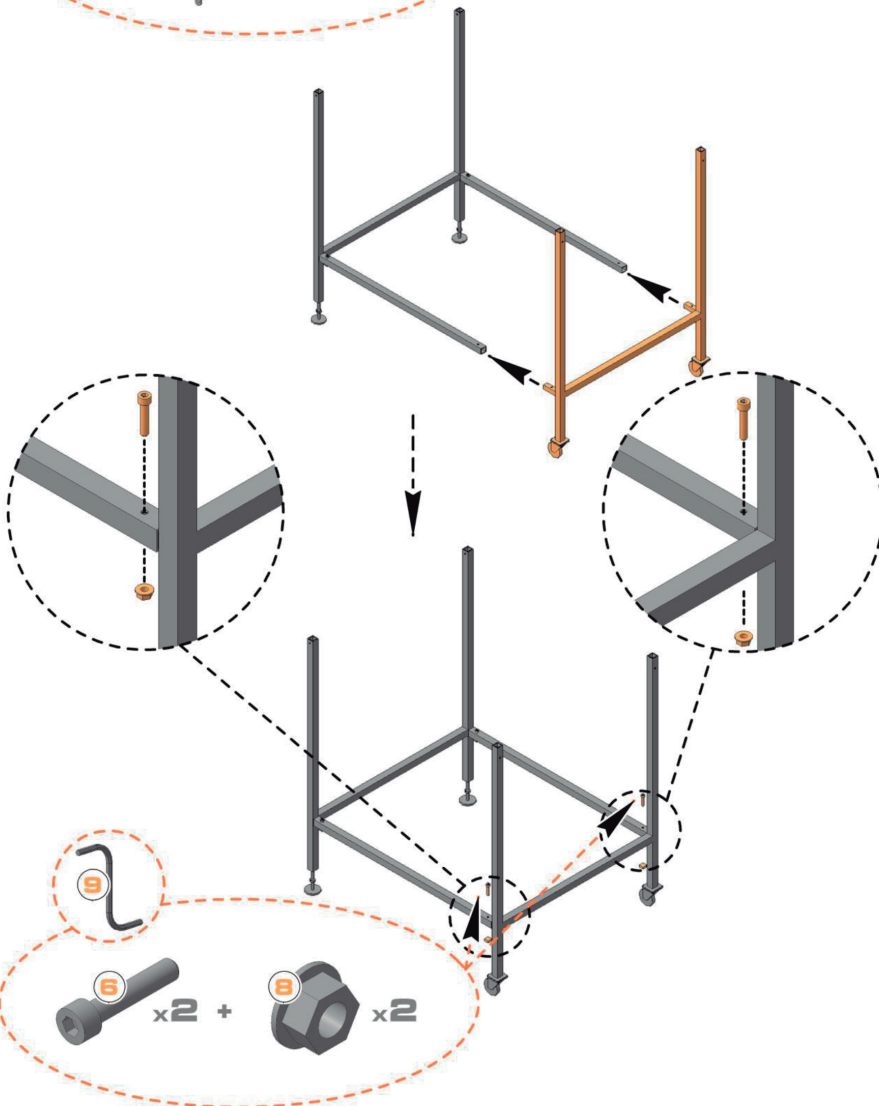

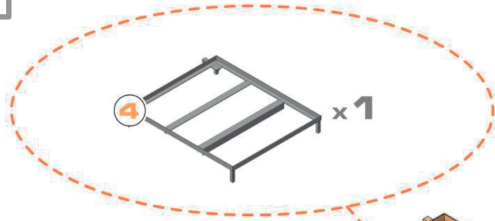
3

Mount part №4, screw it up with bolts №6 and nuts №8, using hex key №9.

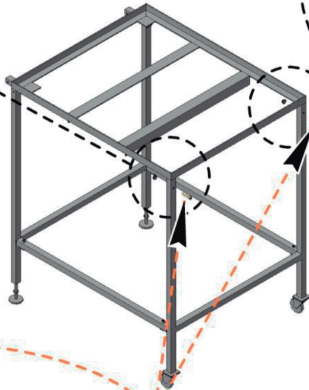
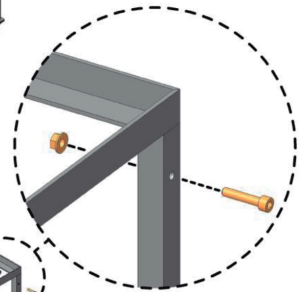
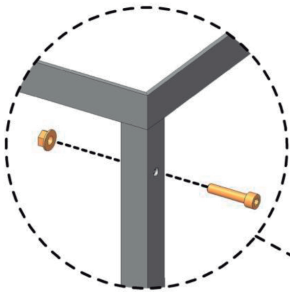

4

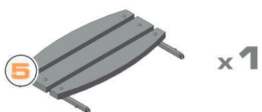

Attach part №5 to part №4, tighten it with bolts №7 and nuts №8, using hex key №9

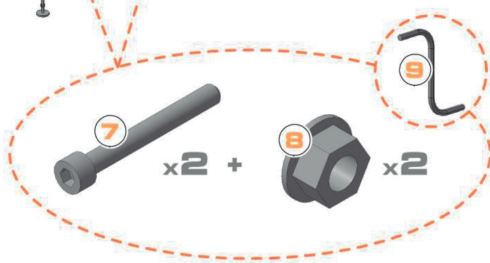
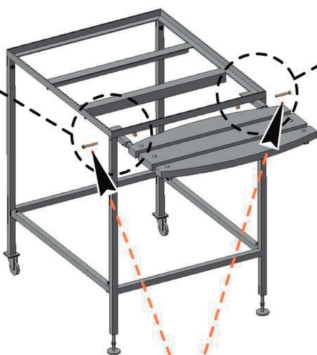
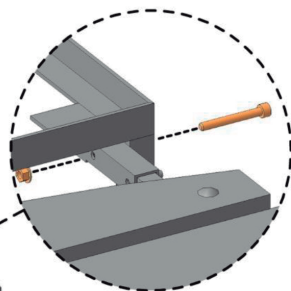
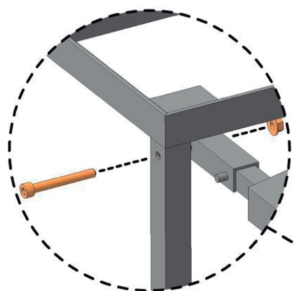
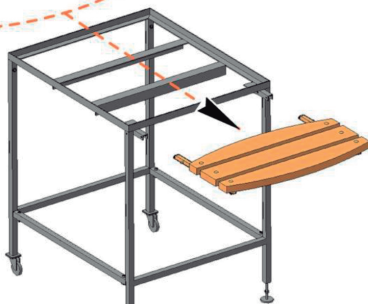

OPERATION MANUAL

The table can be installed on any surface. To do so, adjust the table-legs № 1 for height. Rotating the table-leg clockwise or anti-clockwise, you can adjust it for height.

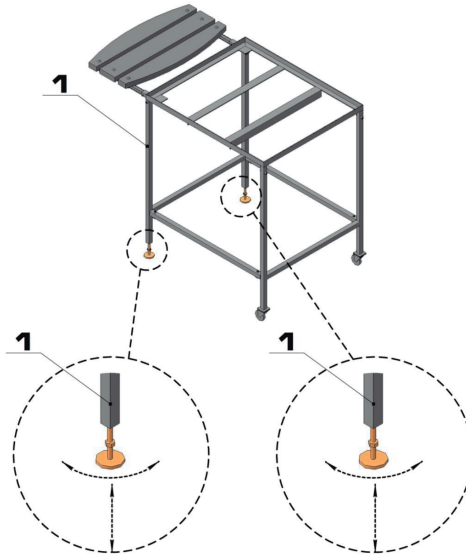

The design envisages 2 positions of part № 5 for ease of storage. To remove the table-flap into the low position, feel for two latches at the joint of details № 4 and № 5. Upholding part № 5, press the latches and press the part down.

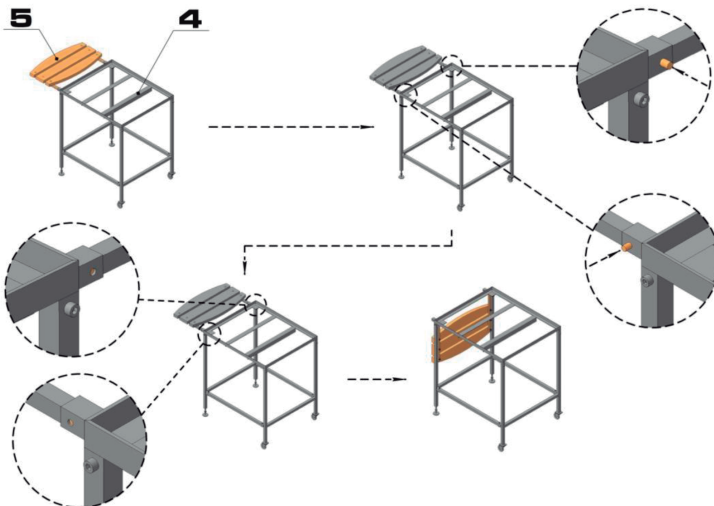



GIRTECH.COM.UA